

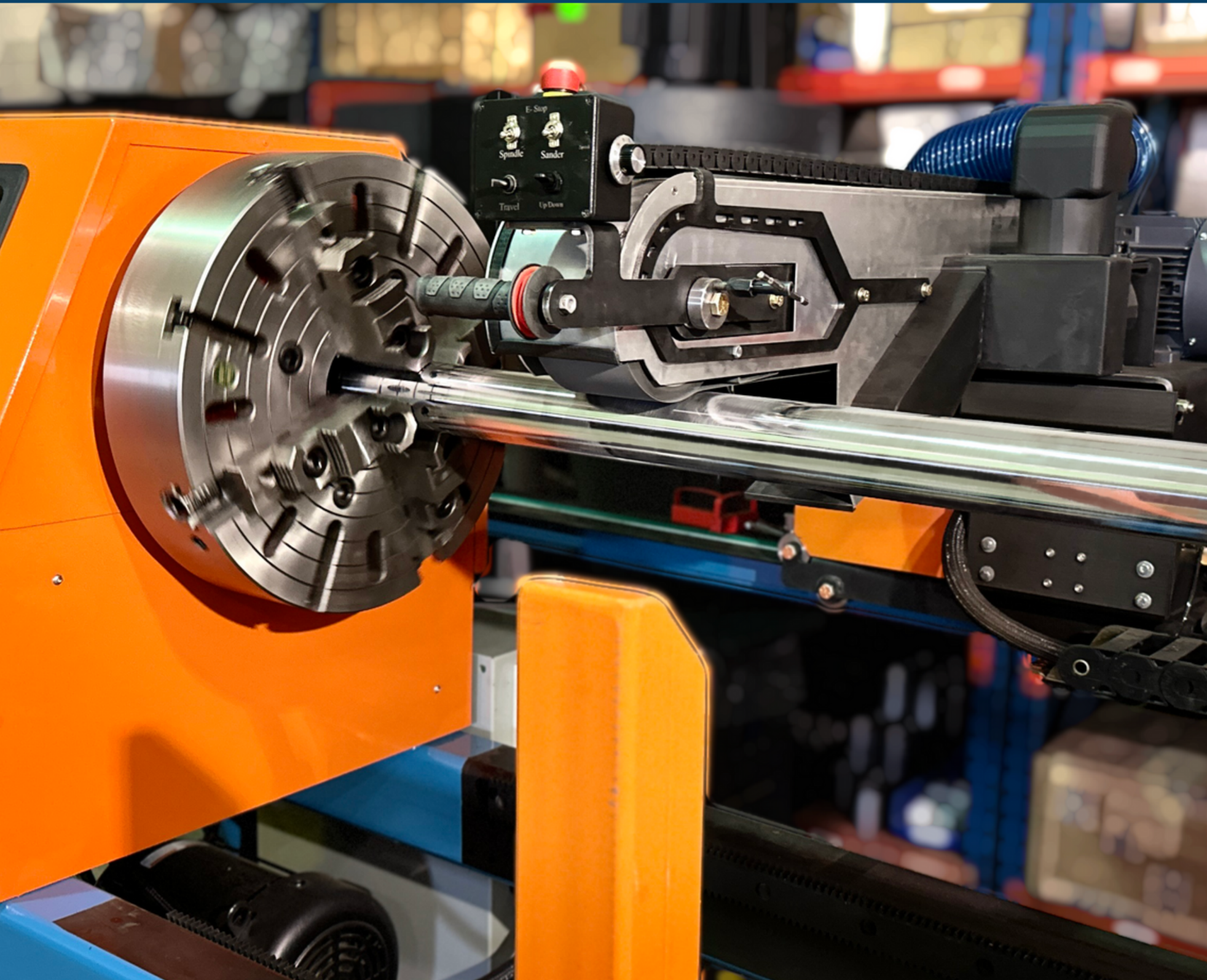

HYDRAULITECHS



**ROD POLISHER**







# ROD POLISHER

## AUTOMATIC/MANUAL FEED SYSTEM

APR-24 /MPR-24

Our rod polishers come in two distinct models to meet various needs: Fully Automated, APR-24 and Manual, MPR-24. The Fully Automated Rod Polisher is designed for high efficiency and precision, offering automated control and minimal manual intervention, perfect for large-scale operations. The Manual Rod Polisher provides more hands-on control and is ideal for smaller workshops or specialized applications where flexibility and precision are required.

### APR-24 (AUTOMATIC MODEL) CAPABILITIES

APR24 Rod polisher is a high-quality, reliable machine designed for efficient and precise polishing of rods. It features a manual and automatic Full PLC/VFD system, providing greater flexibility and ease of use. With a 10 horsepower, VFD controlled 1,750 RPM PMAC motor as the spindle drive, 3 horsepower, 3600 RPM sander drive and ¼ horsepower DC variable motor as the sander head travel drive, this machine allows for easy adjustment of the RPM of the rod, from 0 RPM to 300 RPM.







# ROD POLISHER BENEFITS

APR-24

- **Efficient and Precise:**  
The APR24 is designed for efficient and precise polishing of rods, ensuring consistent results every time.
- **Safe and User-Friendly**  
The machine features adjustable limit switches and rollers for safety, as well as an easy-to-use control panel.
- **Versatile**  
The frequency drive and adjustable sanding belt make this machine versatile for various polishing and repair jobs.

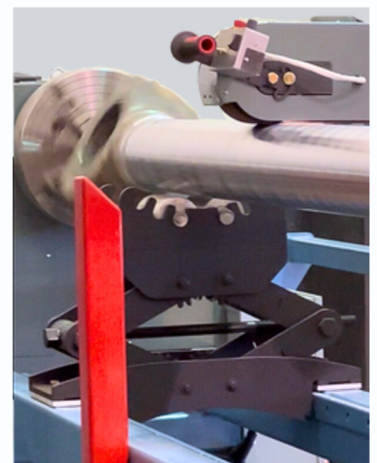

## WHO CAN BENEFIT FROM ROD POLISHER

Mining, oil and gas, forestry, marine, Hydraulic shops and construction industry benefit from the HONIX-WS.







# ROD POLISHER FEATURES

APR-24

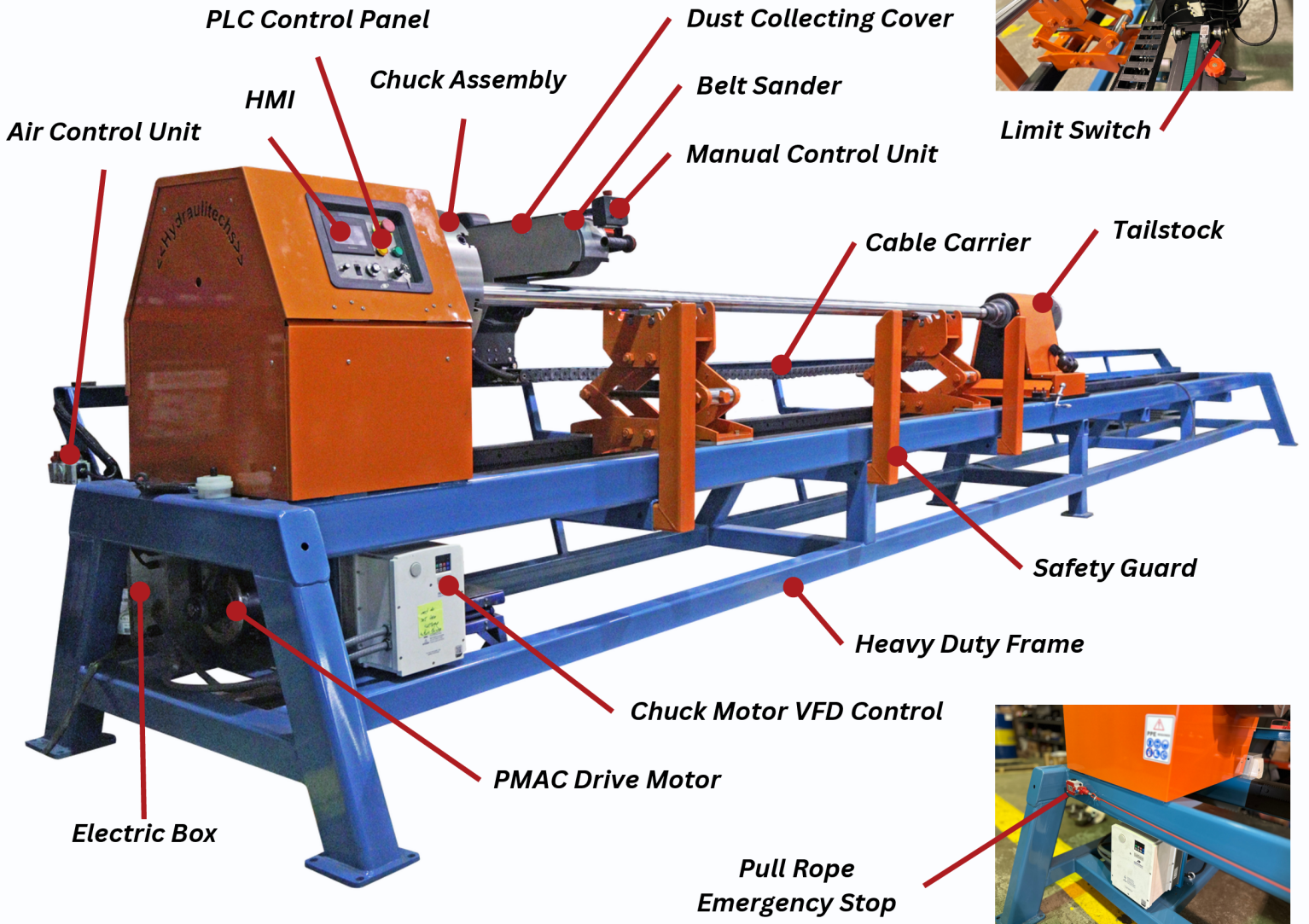
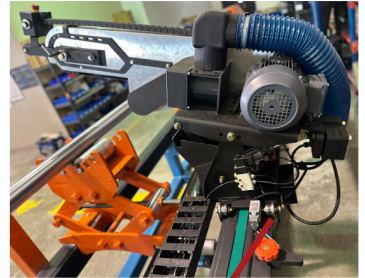

## APR-24 (AUTOMATIC) FEATURES

- Polishing Head
- Dust Collecting Cover
- Position Adjustment Limit Switch
- Electro Pneumatic Sander Engagement
- Electrical Cabinet / Control Cabinet
- Automatic / Manual Feed System
- Cycle Counter Control
- Sander Pressure Control
- Manual and Automatic full PLC/VFD System
- Emergency Stops and safety guards
- Optional fire proof dust collector vacuum with filtration system







# ROD POLISHER SPECIFICATIONS

## APR-24 , AUTOMATIC

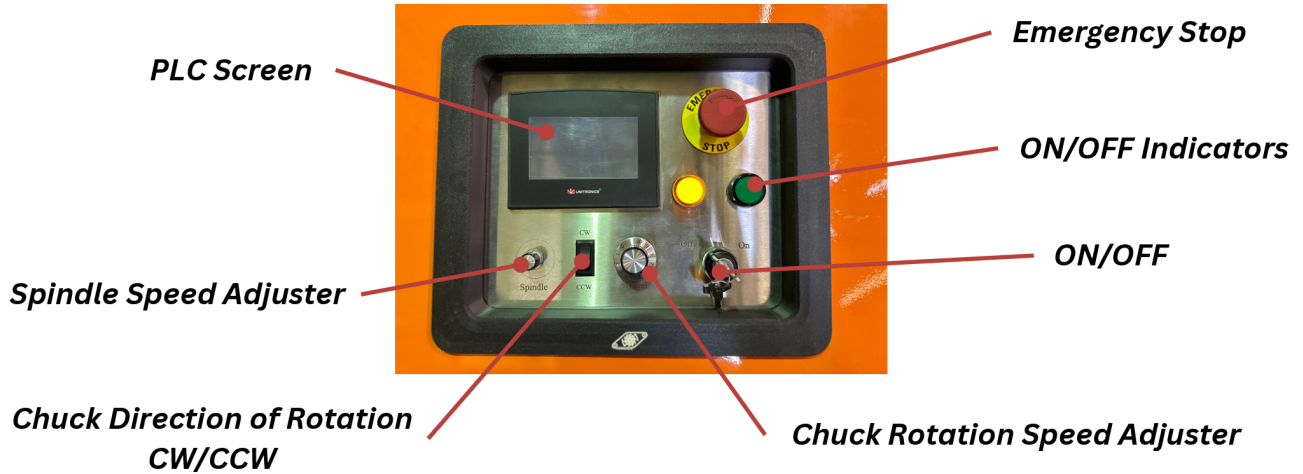

### MACHINE DIMENSIONS:

- ROD POLISHER TOTAL LENGTH:  
MODEL APR-24 .....29 FT

- MACHINE HIGHT ..... 64 IN
- MACHINE WIDTH ..... 71 IN

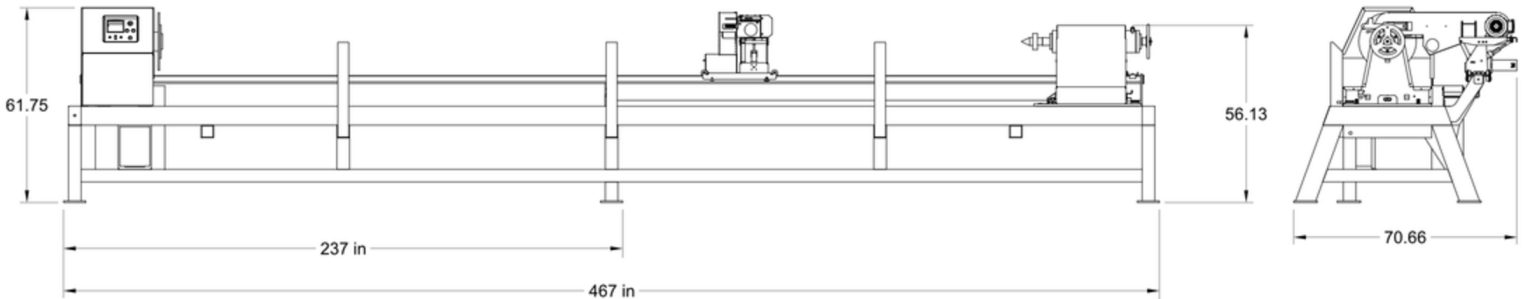

-All dimensions are in inches

### CONSUMABLES:

- ELECTRICAL BOX and PLC CONTROL PANEL
  - FUSE 6A
  - FUSE 3A

### -SANDER BELT

- 4" \* 90" ALUMINUM OXIDE SANDER BELT

### -AIR CONTROL UNIT

- AIR SYSTEM LUBRICATION OIL







# ROD POLISHER SPECIFICATIONS

## APR-24 , AUTOMATIC

### TECHNICAL SPECIFICATIONS:

- VOLTAGE 380-440 V, 3 ph., 60 HZ
- AMP 20 AMP
- MAX LENGTH OF ROD 20 ft
- MIN LENGTH OF ROD 18 inch
- MAX EXTERNAL RODDIAMETER 15 inch
- MIN EXTERNAL ROD DIAMETER 1 inch
- MAX ROD WEIGHT 10,000 lb
- MAX WIDTH OF EYE ON ROD 12.5 inch
- MAX DIAMETER OF EYE ON ROD 24 inch

### CHUCK

- MODEL GATOR20"
- DIAMETER 20 inch
- NUMBER OF JAWS 4 INDEPENDENT
- BELTS 2 B102

### SPINDLE MOTOR

- VOLTAGE PMAC 10 hp WITH VFD
- SPINDLE SPEED CONTROL RANGE 0 TO 300 rpm

### SANDER

- MOTOR 3 HP, 3450 RPM
- SAND BELT WIDTH 4 IN
- DUST COLLECTION PIPE 3 IN
- SAFETY COVER YES

### TAIL STOCK

- SIZE OF #6
- ADJUSTABLE YES
- LOCKING SYSTEM YES

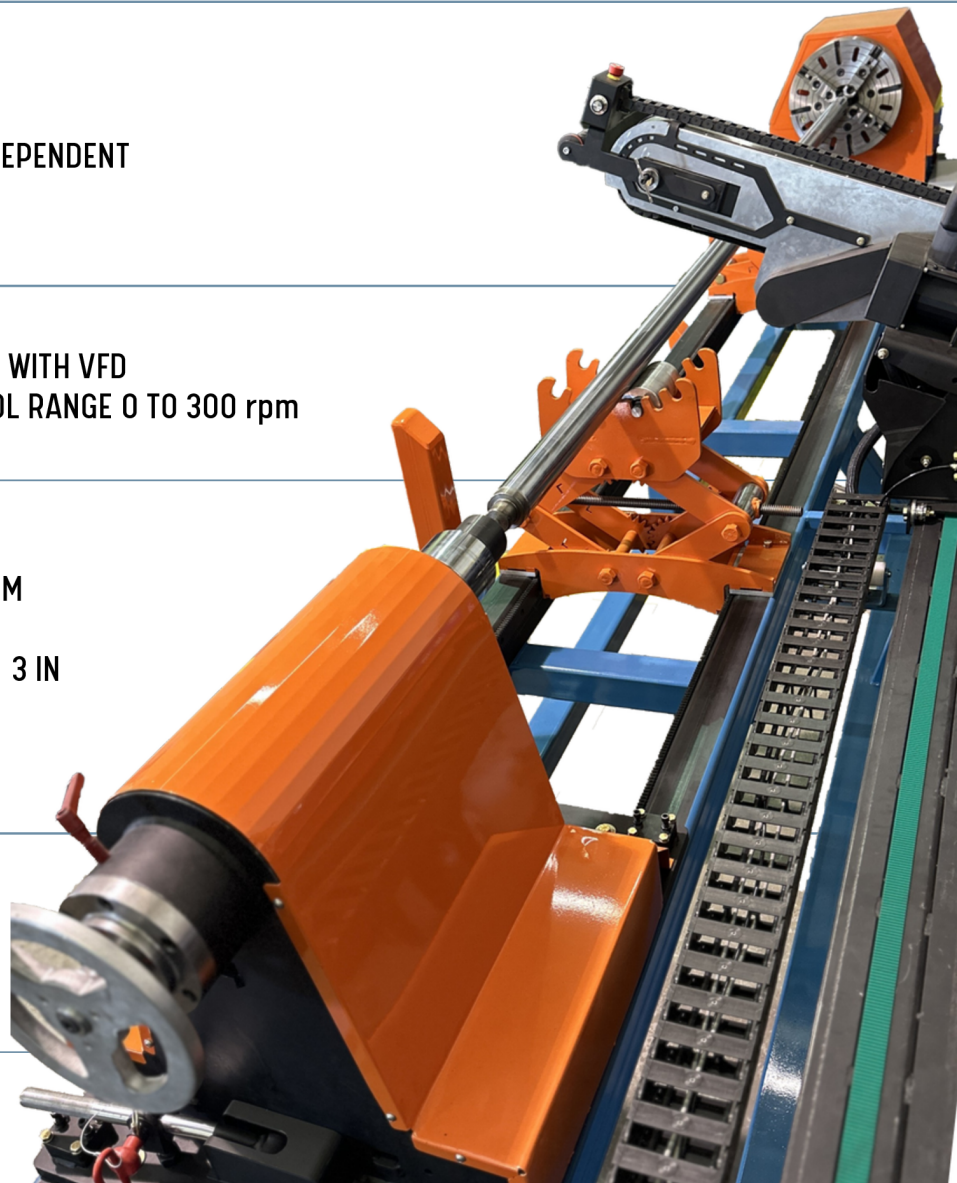



# ROD POLISHER MANUAL MODEL FEATURES

## MPR-24

The MPR24 is a high-quality, user-friendly manual machine. It features a VFD system for precise control, powered by a 2/5 hp, 1750 rpm AC motor for the spindle drive. Additionally, it includes a 3 hp, 3600 rpm motor for the sander drive. The VFD allows for easy adjustment of the rod's RPM from 0 to 300, providing flexibility and efficiency in operation.

### MPR-24 (MANUAL) FEATURES

- Polishing Head
- Dust Collecting Cover
- VFD System
- Emergency Stops and safety guards

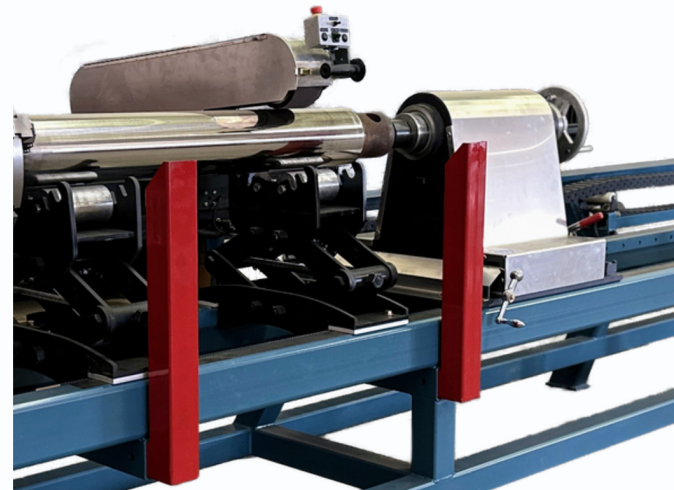

# ROD POLISHER SPECIFICATIONS

## MPR24, MANUAL

### TECHNICAL SPECS:

- VOLTAGE 380-440 V, 3 ph., 60 HZ
- AMP 20 AMP
- MAX LENGTH OF ROD 15 ft
- MIN LENGTH OF ROD 18 inch
- MAX EXTERNAL ROD DIAMETER 10 inch
- MIN EXTERNAL ROD DIAMETER 1 inch
- MAX ROD WEIGHT 2,000 lb
- MAX WIDTH OF EYE ON ROD 8 inch
- MAX DIAMETER OF EYE ON ROD 8 inch

### SPINDLE MOTOR

- VOLTAGE AC MOTOR 2/5 hp WITH VFD
- SPINDLE SPEED CONTROL RANGE 0 TO 300 rpm

### SANDER

- MOTOR 3 hp, 3450 rpm
- SAND BELT WIDTH 4 inch
- DUST COLLECTION PIPE 4 inch
- SAFETY COVER YES
- 4" \* 90" ALUMINUM OXIDE SANDER BELT

### TAIL STOCK

- SIZE OF #4
- ADJUSTABLE YES
- LOCKING SYSTEM YES

### CHUCK

- MODEL GATOR20"
- DIAMETER 16 inch
- NUMBER OF JAWS 4 INDEPENDENT
- BELTS 2 B102

### MACHINE DIMENSIONS:

- ROD POLISHER TOTAL LENGTH:  
MODEL MPR-24 .....20 ft
- MACHINE HIGHT ..... 64 inch
- MACHINE WIDTH ..... 71 inch







HYDRAULITECHS

contact@hydraulitechs.com



[www.hydraulitechs.com](http://www.hydraulitechs.com)

+1-306-683-1960

2215 Faithfull Ave, Saskatoon, SK S7K1T8, Canada

